

STELLAR AGGRESSOR™

9000 OTR



Convenient. Powerful. Aggressive. The Stellar 9000 OTR series tire service crane packs it all into one unit. This truck is the one to turn to when you need a reliable and dependable Class 6 (26,000 GVW) service truck to serve your customers. The 9000 also works exceptionally well on a Class 7 chassis to allow for greater payload. The 90,000 foot-pound crane has a maximum lift capacity of 15,000 lbs. @ 6' and 6,000 lbs. @ 15'. The crane rotation is 290°, achieved through a turntable bearing with an external hour glass shaped worm gear. The hexagon shaped secondary and extension boom greatly increase boom strength over competitive square-shaped booms, ensuring solid performance.



The tire sizes the 9,000 lb. crane can lift include the 36.00-51 mounted narrow base and 50/65-51 wide base tires. The performance of the 9000 OTR series can be enhanced by the addition of the

TM4110 Tire Manipulator. The TM4110 allows versatility while providing a safe method to handle a variety of OTR tires.



The TM4110 Tire Manipulator offers 140° of articulation and 240° of body rotation. This allows the operator to work in a variety of conditions. The TM4110 has a clamping span of 50" to 104" and can handle tires or tire-rim combinations up to 4,600 lbs. The variation of clamping distances gives the 9000 OTR series with a TM4110 Tire Manipulator the ability to service fleets with small to medium sized OTR tires.

9000 OTR Series

STELLAR AGGRESSOR™ 9000 OTR



The Stellar 9000 OTR series is the only crane in its class to offer a variable speed handheld radio remote control as a standard feature. The radio remote control system allows operators to maintain a safe operating distance between themselves and the load. A push button on-off switch in the pistol grip handle ensures that the crane is activated only by the operator.



The heavy duty OTR body shown below is designed to meet the medium OTR needs. Features include underbody tool compartments with slide top doors equipped with stainless steel automotive style slam latches. Other features include D-ring tie downs, recessed skirt-mounted halogen floodlights, DuPont Imron 5000 paint, and complete body undercoating. A heavy duty frame mounted push bumper is mounted at the rear of the body.



Model SHD-66DD direct drive hydraulic air compressor is a 4-cylinder, 2-stage compressor with 63.51 displacement CFM @ 175 PSI. The compressor is neatly mounted on the crane base to the right of the crane mast.

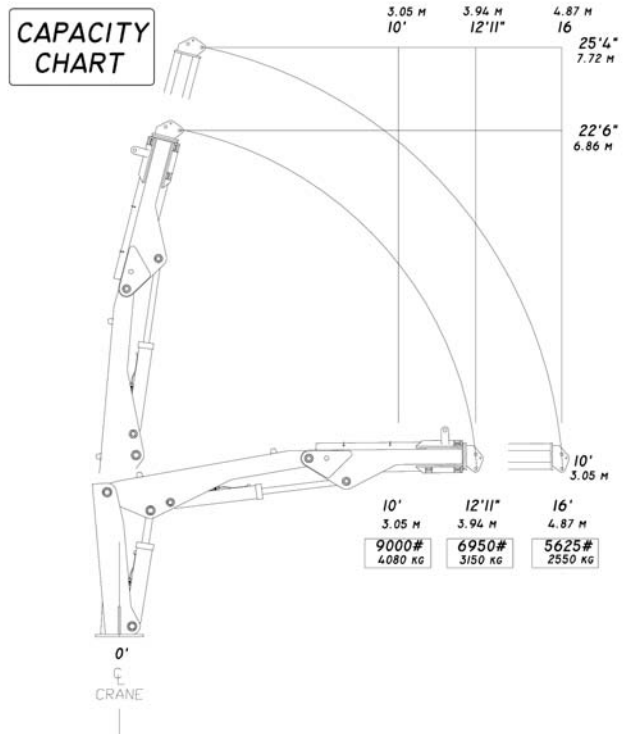

The chart above shows the lifting capacities and reach for the 9000 crane **without** the TM4110.



190 State Street
 Garner, Iowa 50438
 1-800-321-3741
 Fax: 641-923-2812
 E-mail: sales@stellarindustries.com
 www.stellarindustries.com

Designed & Manufactured in the U.S.A.

*Specifications may change without notification.
 Copyright © 2009 Stellar Industries, Inc.